

Cashmaster *printer five* User Manual

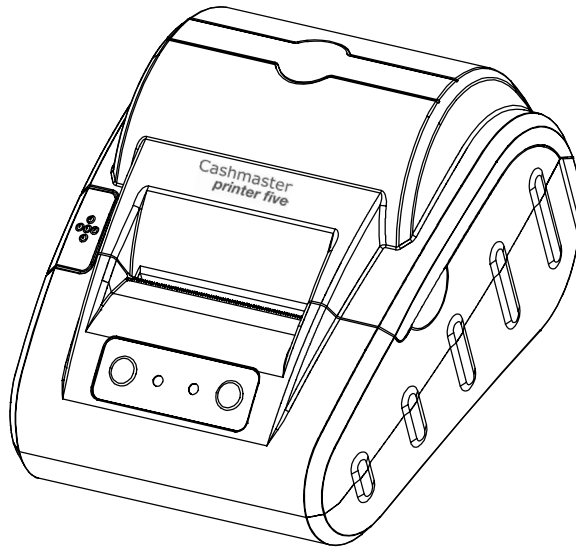

Contents

Product Features.....	1
Buttons and Indicators.....	1
Connecting the Printer.....	2
Installing Paper.....	2
Using your Printer.....	3
Troubleshooting.....	4
Specification.....	4
Global Support.....	5

Product Features

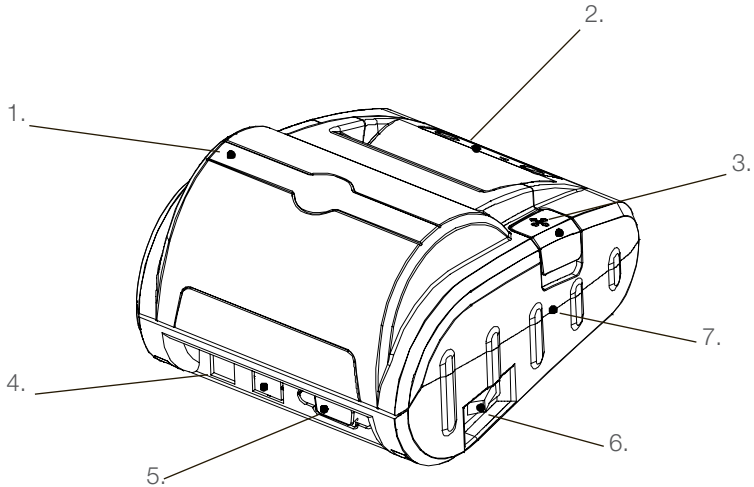

1. Paper cover (as used in **Installing Paper**, Page 2, Point 2)
2. Control panel
3. Cover release button
4. Power socket
5. Serial cable interface
6. Power switch
7. Main body

Buttons and Indicators

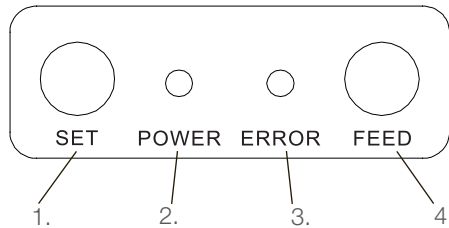

1. Set button – Factory / trouble shooting use only
2. Power LED – indicates when the printer is turned on
3. Error indicator – indicates errors. Flashing when the paper has run out
4. Feed button – feeds paper through the printer

Connecting the Printer

1. Connect the printer to your Cashmaster counter using the serial cable provided:

ProNote:
Cashmaster One:

PN 000823
PN 000766

2. Plug the AC adapter into the power supply socket and switch on the mains supply.



Warning: Only use the supplied Cashmaster Printer 5 power adapter, part number 04892 and labelled "Only for use with Cashmaster Printer Five". Connecting a power adapter from a Cashmaster money counter, or other device, may cause permanent damage.

Installing Paper



Warning: Hot surface. Do not touch the print head.

The paper roll should be changed when the red ink end of roll indicator is observed on the print output. A new roll should be installed before the end of the paper is reached to prevent partial printing or feeding errors.

1. Turn off the printer using the power switch [5].
2. Push the cover release button [3] to release the paper cover and reveal the paper chamber.
3. Remove the used paper roll, if present. Insert the new roll, orientated so that the free end unspools from the bottom of the roll, towards the front of the printer.

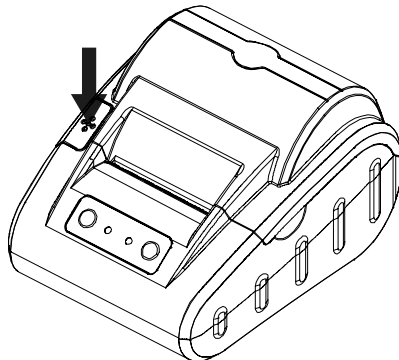

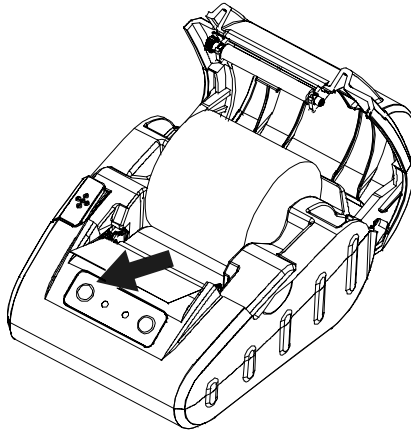

4. Unspool sufficient paper to lay it over the tear off strip, and then close the cover.
5. Turn the printer on. Verify that the power LED is illuminated, and no errors are indicated.
6. Press the feed key, checking the paper feeds correctly.
7. Tear off the excess paper.

Using your printer

1. Turn the printer on.
2. Verify that the power LED is illuminated, and no errors indicated.
3. When you are ready to print your count, press the print button on your Cashmaster counter.
4. To feed additional paper if required, push the feed button.
5. When the print is complete, tear off the paper using a sideways motion:

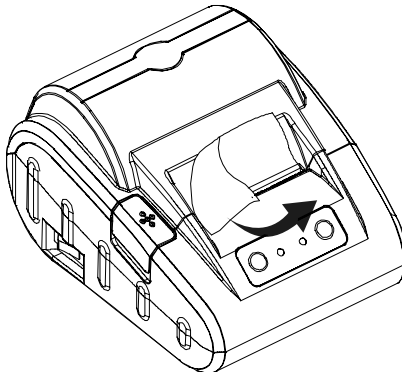

Troubleshooting

Error LED flashing	Paper out, or paper cover not closed. Open the cover and check the paper. Verify that the paper is loaded in accordance with the ' Installing Paper ' section.
Power LED not illuminated	Check that the printer power switch [5] is turned on, and the external power adapter is correctly plugged in to the device and mains power socket.
Paper feed error / jam	Open the paper cover and clear the jam. Ensure the paper is correctly installed in accordance with the ' Installing Paper ' section.
Print timeout	Check that the printer serial cable is correctly installed to the money counter and printer.
Self test	Press and hold the FEED button while turning the printer on. The printer will automatically print a self test receipt.

Specification

Print method	Direct thermal
Paper roll	Width: 57.5 +/- 0.5mm Maximum OD: 62mm Minimum ID: 13mm Thickness: 0.05 – 0.08mm
Power supply	7.5V DC, 2A
Interface	Serial
Operating temperature	10°C to 40°C

Global Support

Hong Kong and Asia

t: +852 2157 9363

e: enquiriesasia@cashmaster.com

Germany

t: +49 (0) 2463 999 339

e: germany@cashmaster.com

North America

t: +1 877 227 4627

e: inquiriesusa@cashmaster.com

UK and all other customers

t: +44 (0) 1383 410 121

e: support@cashmaster.com

cashmaster.com



www.cashmaster.com